

**ADC COMPACT
RISLINK TOOLKIT
SOFTWARE**

USER MANUAL

TABLE OF CONTENTS

GENERAL	1
RIS FUNCTIONALITY IN THE ADC COMPACT ID SOFTWARE	2
RIS ACTION FLOW	3
RISLINK AND THE RIS DATA FILE	6
Gaining direct access to the RIS data file	6
Using Rislink with a DOS executable	10
Using Rislink with a Windows executable	14
Using Rislink with a mapped worklist	18
Using Rislink with a DICOM RIS Worklist	23
Using Rislink with an Accession Number	41
RIS FIELD MAPPING	45
RIS value validation	48
RISLINK FILE FORMATS	49
Parameter file format	49
RIS WORKLIST file format	50

General

This manual describes the functionalities of the Rislink Toolkit for the ADC Compact system, to be installed as an add-onto the ADC Compact ID software.

The Rislink Toolkit is an optional licensed toolkit, sold as a separate product, which permits the user to create a link between the ADC Compact ID software and a RIS system. Patient data can be downloaded to the ID station, and in a later version, feedback data can be uploaded to the RIS system. Extra functions that have been added since the release of the ADC70 Rislink Toolkit is the possibility of accessing the RIS through a mapped worklist, a DICOM RIS worklist and the Accession Number.

Agfa is not responsible for the connection between the RIS system and the ID station PC. Your Agfa representative can advise you on which software package you can use to connect to the most common RIS systems.

RIS functionality in the ADC Compact ID software

The RIS can be accessed in several different modes.

- Gaining direct access to the RIS data file
- Using a DOS executable
- Using a Windows executable
- Using a mapped worklist
- Using a DICOM RIS worklist
- Using the Accession Number

Each time a cassette is entered and RIS is activated, a sub-process written by the user is called. In this sub-process the user creates a RIS data file containing the RIS identification data that will be used to be filled out in the Identification screen.

Every identification field has an ACR-NEMA code (old format) or a DICOM code (new format). For more information we refer to the section "RIS field mapping" on page 45 of this manual.

When a field is missing in the RIS data file, the default value is taken. See under "RIS value validation" on page 48.

The RIS services support the current Rislink (DOS-based) Toolkit, based upon NFS file transfer. The ADC Compact ID software supports the file format of the DOS-Rislink version, but should be used with NFS (windows 95) and NTFS (windows NT). The RIS data is displayed in a DOS window.

RIS action flow

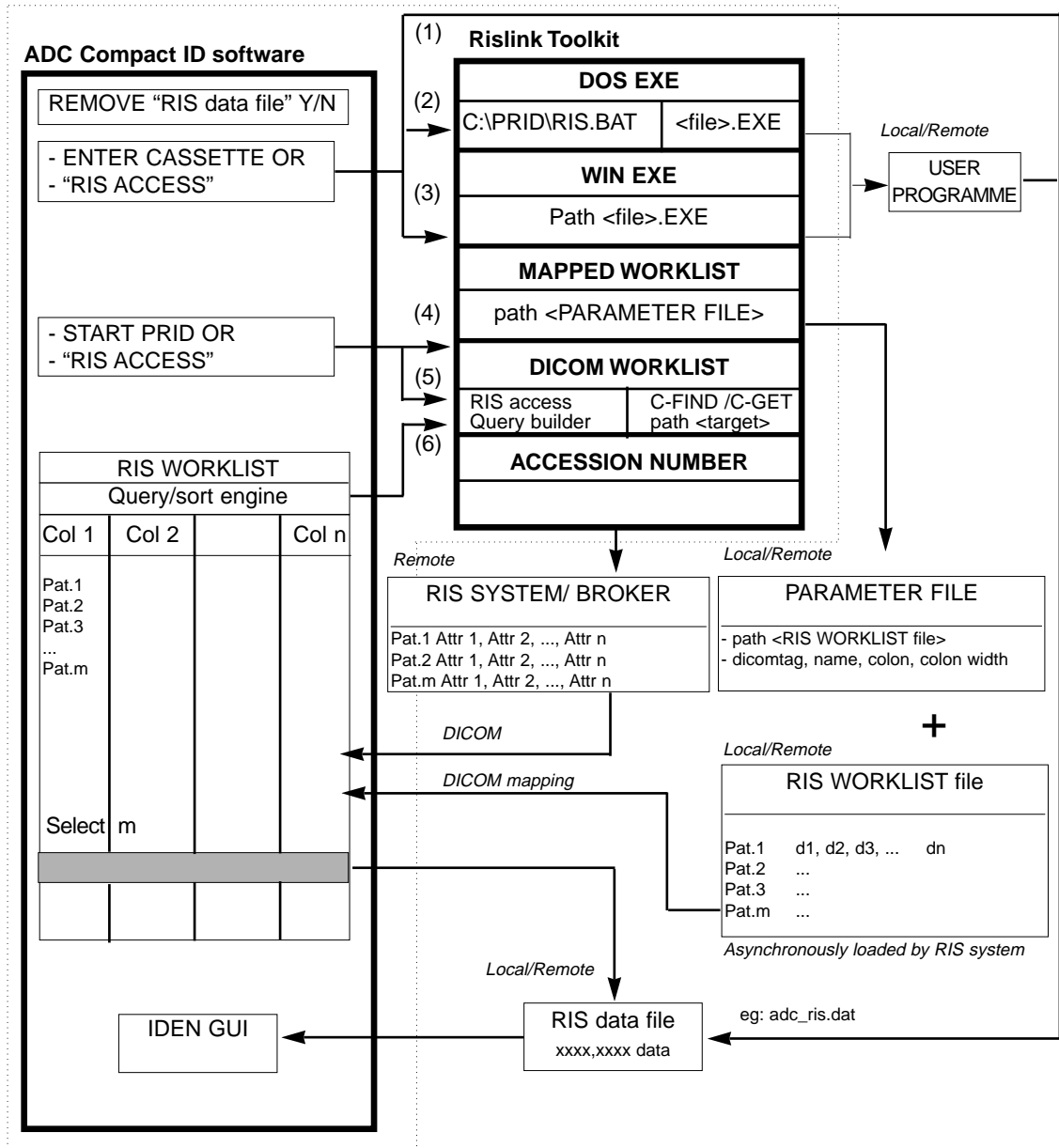

Creating a data file

As already stated, the RIS data file can be produced in several ways. The user is responsible for the creation of this file, which must comply with the ACR-NEMA format or the new DICOM format. The data in this file is extracted from the Radiology Information System (RIS) of the hospital.

The creation of this file is not the subject of this manual. However, the following is an extract from a RIS data file:

```
0019,1001,V1      (New RIS format: V1) see under "RIS field mapping" on
                  page 23.
;
;PatientName & Firstname
0010,0010,Mr. Lim ^Po Kiam
;
;PatientID
0010,0020,img7_ID
;
;PatientSex
0010,0040,1
;
;Wait flag
0019,1072, 0
;
;PatientBirthDate
0010,0030,19960916
;
;Name of Physician(s) Reading Study
0008,1060,AGFA DEFAULT M
;
;StudyID
0020,0010,std_img7
;
;Referring Physician's Name
0008,0090,ADC_SQA
;
;tags.Comment
0020,4000,Comment_img7
;
```

```
;Patient Weight
0010,1030,img7_weight
;
;Ethnic group
0010,2160,img7_ethnic_grp
;
;User_Info_3
0019,10FC,img7_Info_3

etc.
```

Rislink and the RIS data file

Gaining direct access to the RIS data file

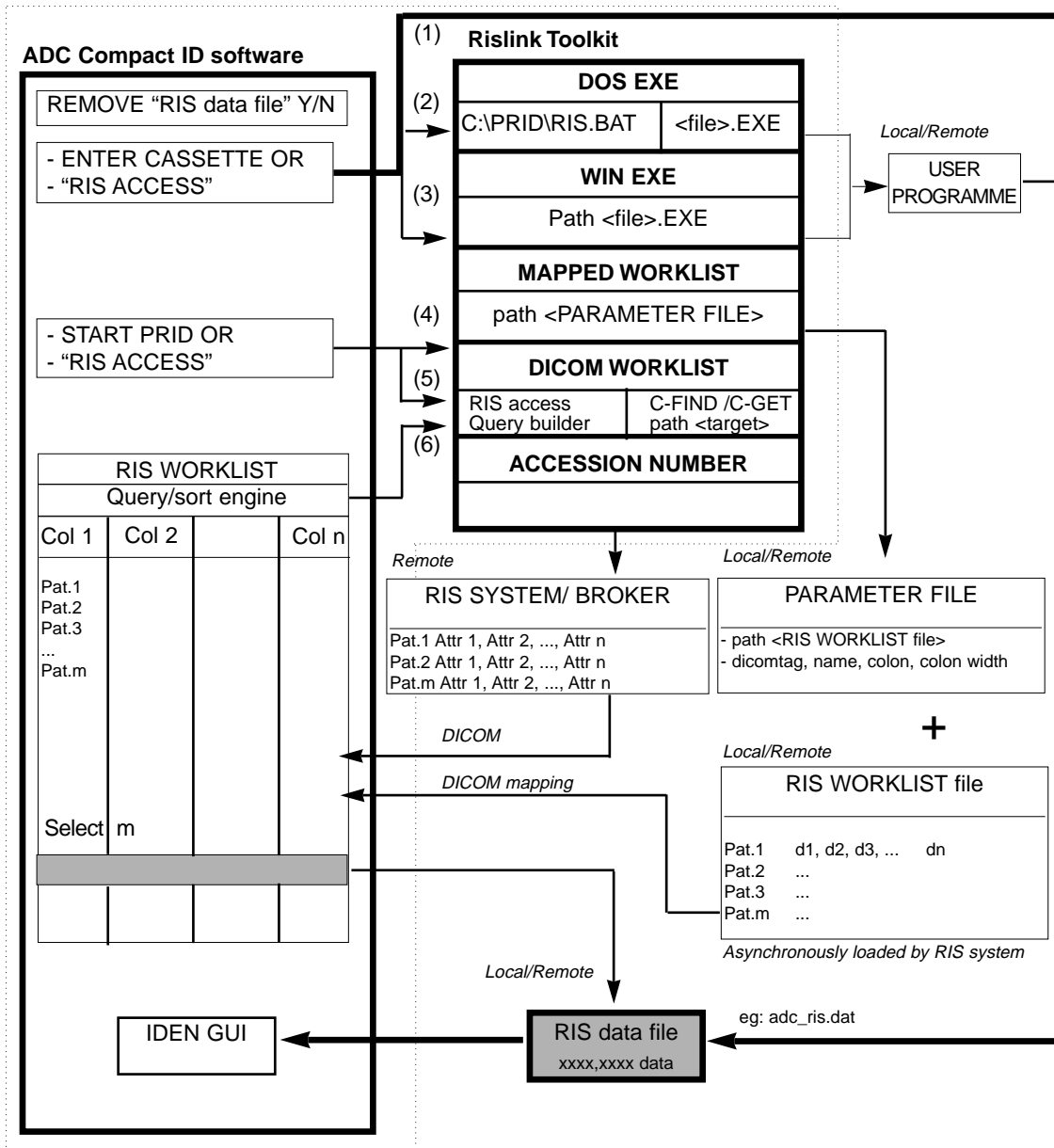

To gain direct access to the RIS data file, select RIS settings as illustrated:

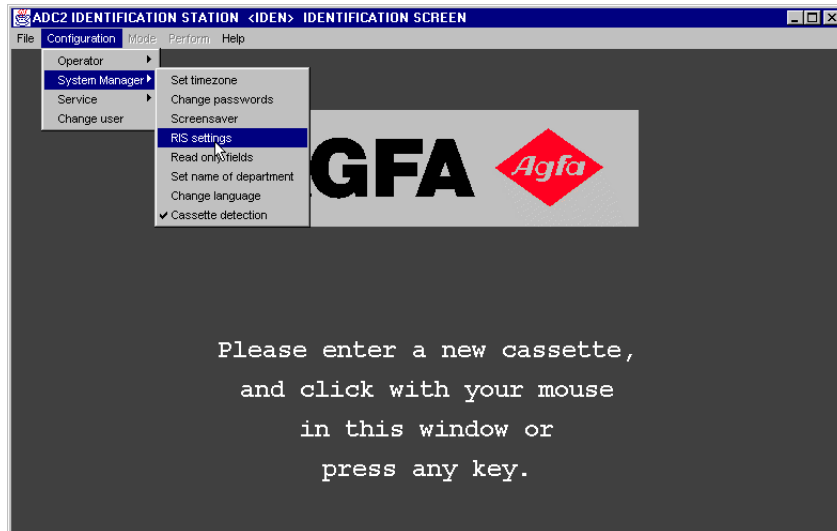

Select the following options:

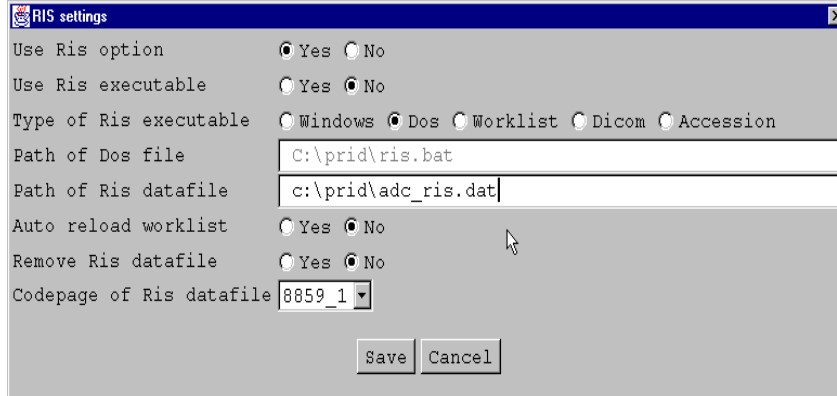

- For “Use RIS option”, select YES.
- The RIS executable is not being used for the present, so click NO.
- The path of the DOS file is fixed but not relevant at this point.

- The path and the name of the RIS data file are defined by the user. In this case: "c:\prid\adc_ris.dat".
- Automatic reload of the worklist will be explained later and should be set to NO for the present.
- "Remove RIS data file": this option enables you to erase the RIS data file after it has been read and written to the cassette.
- Code page of RIS data file: enables you to determine which code page the RIS data file was created with.

Click SAVE to save your settings or CANCEL to abort the operation.

The file c:\prid\adc_ris.dat contains the data that will be used to fill in the fields in the identification screen. See the adc_ris.dat file on pages 4 and 5.

Once the data has been read and approved click the Write function key. The data will now be written to the cassette.

The data can be altered in 2 ways:

- directly on screen.
- by changing the RIS data file. In this case you have to start over again.

The configuration of system files for editable and non-editable fields must be carried out by AGFA service personnel.

Using Rislink with a DOS executable

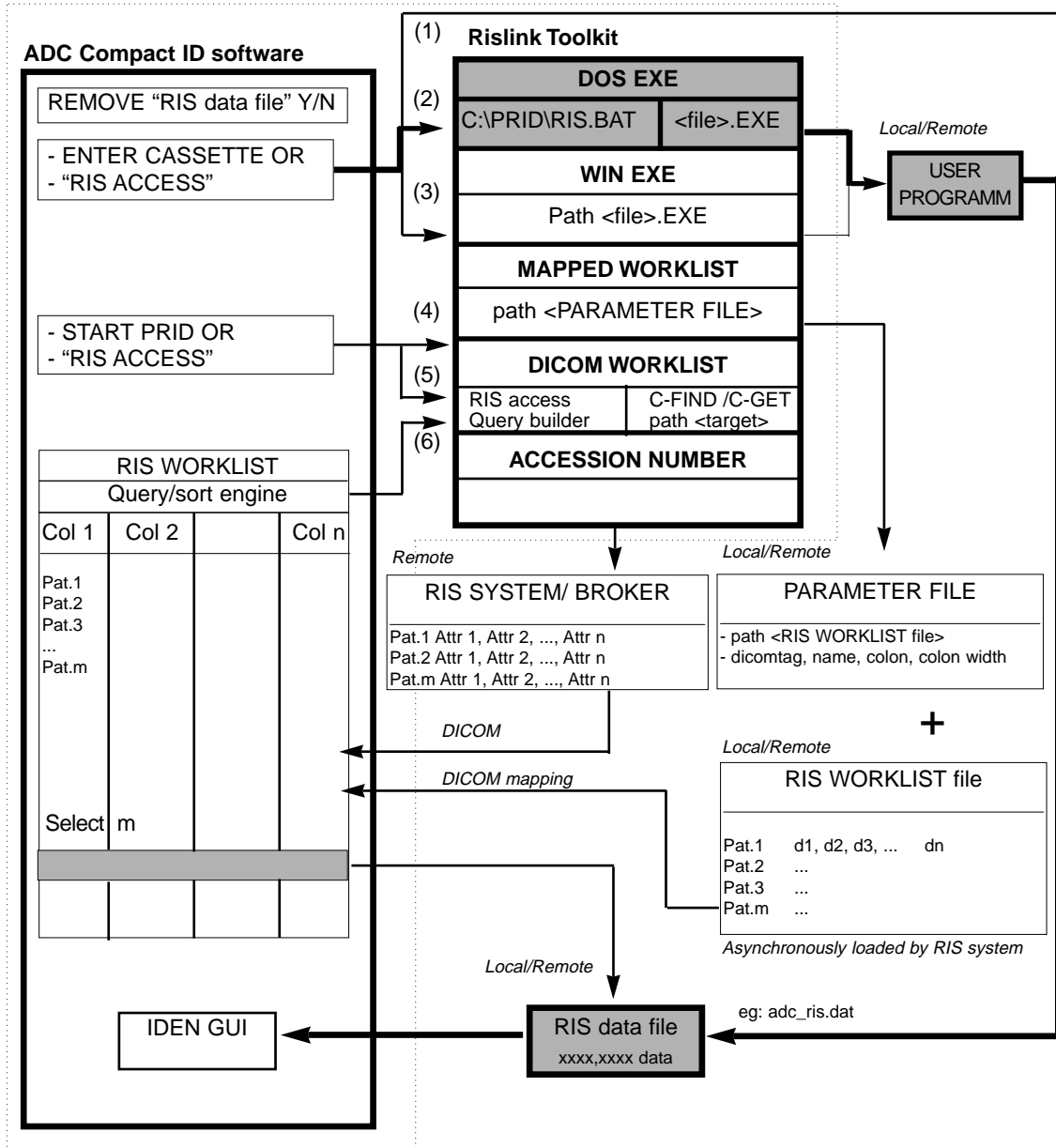

In this case the RIS data file is accessed via a DOS batch script called C:\PRID\RIS.BAT. In this batch file a DOS executable can be mounted, to be called when required.

The user programme that is called delivers a RIS data file (local or remote) with the data to be used to fill in the IDEN GUI. The file name RIS.BAT cannot be changed and the file must reside in the directory c:\prid.

To configure the system proceed as follows:

- Select RIS settings as illustrated:

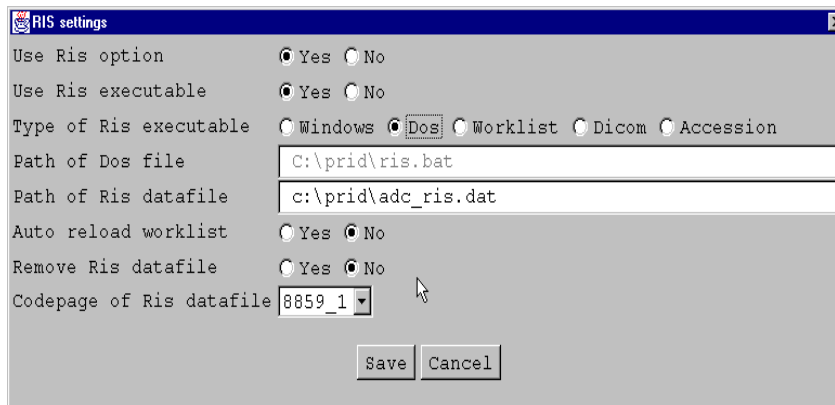

- For “Use RIS option” select YES.
- The RIS executable is being used, so click YES.
- The path and name of the DOS batch file is fixed. Check if the file exists.

The following is an example of the RIS.bat file.
 Suppose the RIS data file is mounted on s:_ADC2_F1\TAG\risfile.dat:

```

@ECHO OFF
IF NOT EXIST c:\prid\adc_ris.dat GOTO CONTINUE
DEL c:\prid\adc_ris.dat

:CONTINUE
ECHO “Waiting for RIS-data...”
:WAIT
IF NOT EXIST c:\prid\adc_ris.dat GOTO WAIT
copy s:\_ADC2_F1\TAG\risfile.dat c:\prid\adc_ris.dat

:END
  
```

- The path and the name of the RIS data file are defined by the user. In this case “c:\prid\adc_ris.dat”.
- Automatic reload of the worklist will be explained later and should be set to NO for the present.
- Remove RIS data file: this option enables you to erase the RIS data file after it has been read and written to the cassette.
- Code page of RIS data file: enables you to determine which code page the RIS data file was created with.

Click SAVE to save your settings.

The file c:\prid\adc_ris.dat contains the data that will be used to fill in the fields in the identification screen. See the adc_ris.dat file on pages 4 and 5.

ADC2 IDENTIFICATION STATION <IDEN> IDENTIFICATION SCREEN

File Configuration Mode Perform Help

PATIENT

Patient Name Mr. Lim Firstname Po Kiam
Birth date 16/09/1996 Patient ID img7_ID
Sex Other Accession number Acc_nr_7

STUDY

Radiologist AGFA DEFAULT
Examination SERVICE Sub examination CHEST PORTABLE

IMAGE

Department AGFA ADC2
Patient position AP
Cassette orientat Landscape Exposure Class 200
Comment Comment_img7

DESTINATIONS

Hardcopy unit ADC_LR1 Number of copies 1
Processing stati ADC_PS1 Film format 14INX17IN
Archive station None
Send station None

F1 Write F2 Clear F3 Recall F4 New patient F7 History F10 Cancel

Ready for identification. |AUTO| 05/06/1997 19:12:14

Once the data has been read and approved, click the Write function key. The data will now be written to the cassette.

Data can be altered in 2 ways:

- directly on screen.
- by changing the RIS data file.

Using Rislink with a Windows executable

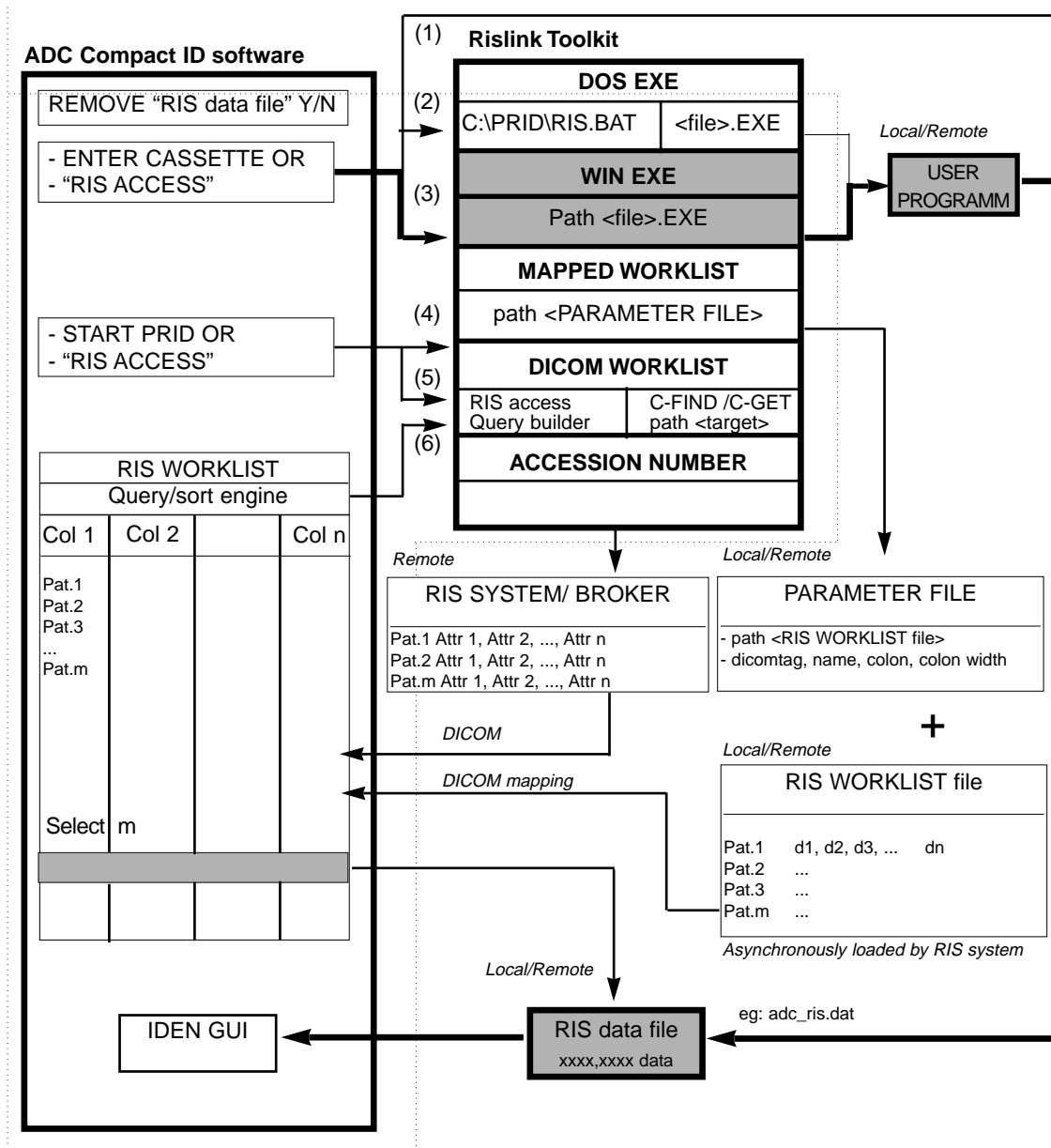

The RIS data file can also be accessed via a WINDOWS executable.

The user programme that has been called delivers a RIS data file (local or remote) with the data to be used to fill in the IDEN GUI.

To configure the system, proceed as follows:

Select RIS settings as illustrated:

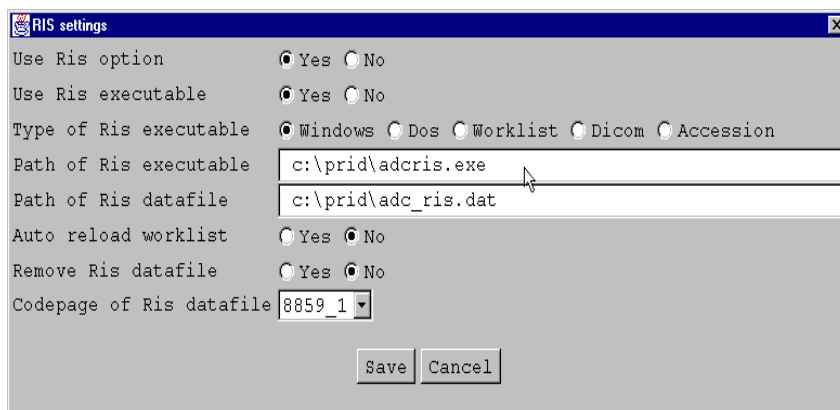

- For “Use RIS option”, select YES.
- The RIS executable is now being used, so click YES.

- The type of RIS executable is Windows.
- Fill in the path and name of the Windows executable (in this example c:\prid\adcris.exe). Check if the file exists.
- The path and the name of the RIS data file are defined by the user. In this example: "c:\prid\adc_ris.dat".
- Automatic reload of the worklist will be explained later and should be set to NO for the present.
- Remove RIS data file: with this option you can erase the RIS data file after it has been read and written to the cassette.
- Code page of RIS data file: enables you to determine which code page the RIS data file was created with.

Click SAVE to save your settings.

The file c:\prid\adc_ris.dat contains the data that will be used to fill in the fields in the identification screen. See adc_ris.dat file on pages 4 and 5.

ADC2 IDENTIFICATION STATION <IDEN> IDENTIFICATION SCREEN

File Configuration Mode Perform Help

PATIENT

Patient Name Mr. Lim Firstname Po Kiam
 Birth date 16/09/1996 Patient ID img7_ID
 Sex Other Accession number Acc_nr_7

STUDY

Radiologist AGFA DEFAULT
 Examination SERVICE Sub examination CHEST PORTABLE

IMAGE

Department AGFA ADC2
 Patient position AP
 Cassette orientat Landscape Exposure Class 200
 Comment Comment_img7

DESTINATIONS

Hardcopy unit ADC_LR1 Number of copies 1
 Processing static ADC_PS1 Film format 14INX17IN
 Archive station None
 Send station None

F1 Write F2 Clear F3 Recall F4 New patient F7 History F10 Cancel

Ready for identification. |AUTO| 05/06/1997 19:12:14

Once the data has been read and approved, click the Write function key. The data will now be written to the cassette.

Data can be altered in 2 ways:

- directly on screen.
- by changing the RIS data file.

Using Rislink with a mapped worklist

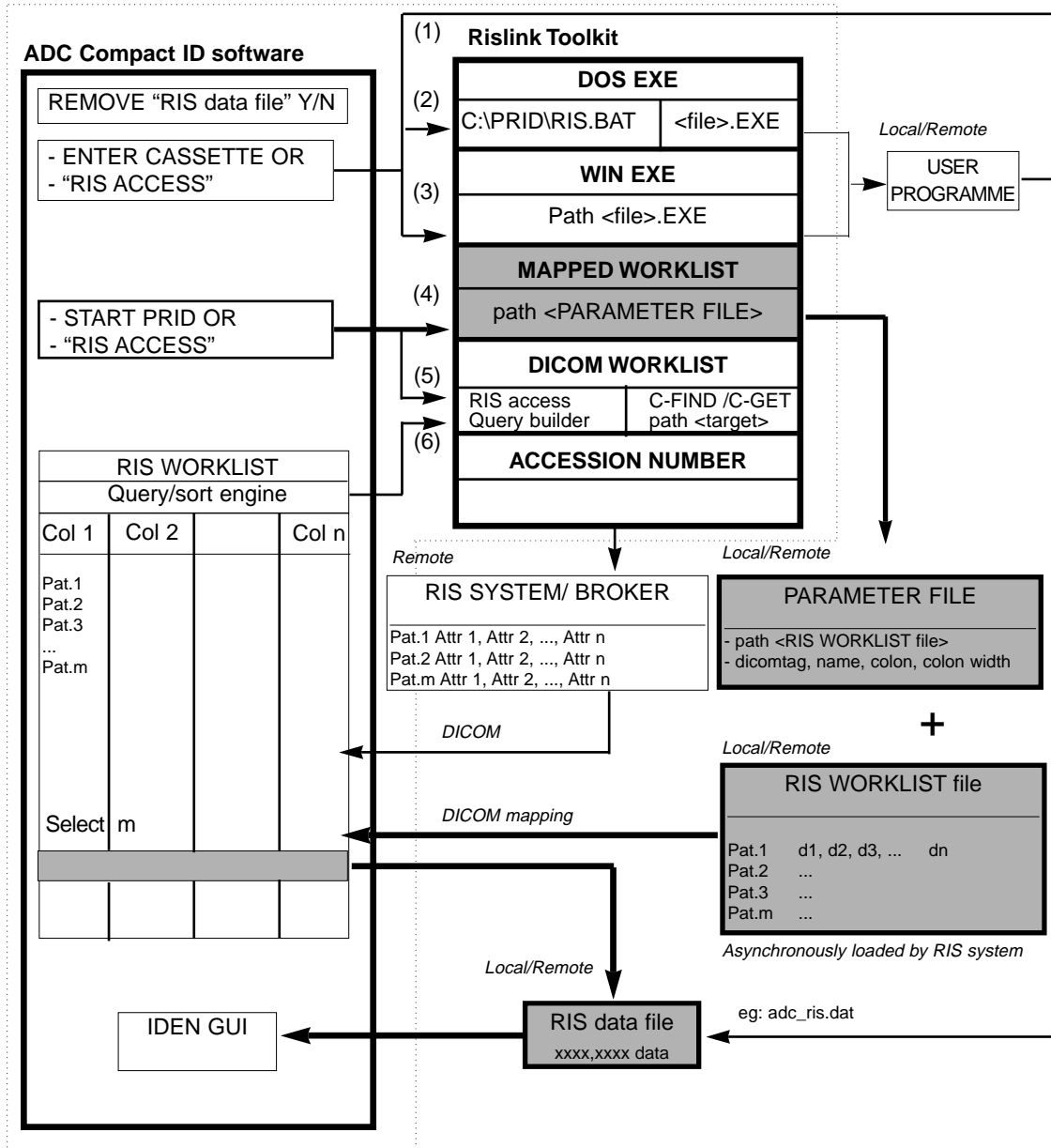

To work with a mapped worklist you need 2 files:

- the RIS WORKLIST file created by the RIS, with filename WORKLIST.TXT and location determined by the RIS (local or remote). The data fields are delimited with “,” in this example.
- a PARAMETER template file PARAM.DAT created by the administrator which converts the delimited data from the RIS worklist file to a RIS WORKLIST with DICOM fields (col1...coln).

The Rislink Toolkit reads the WORKLIST.TXT file by means of the user-defined template file and outputs the result in a file named, for example, adc_ris.dat. The location of this file is determined in the template file PARAM.DAT.

The following is an extract from the PARAM.DAT file:

INPUT:c:\prid\worklist\worklist.txt	<i>path of worklist file to be converted</i>
OUTPUT:c:\prid\adc_ris.dat	<i>path of RIS data file</i>
COPY:c:\prid\Agfa.cop	<i>enter this string as it is</i>
SEPARATOR:;	<i>declare separator of delimited file</i>
FIELD 01:*	<i>field1 of RIS worklist file is not to be converted to a DICOM tag</i>
FIELD 02:0019,2001/PatientName/1/15	<i>field2 is to be converted to DICOM tag 0019,2001</i>
FIELD 03:0019,2002/First Name/2/15	
FIELD 04:0010,0030/Birthdate/3/10	
FIELD 05:0010,0020/PatientID/4/14	
.	
.	
FIELD 33:0019,10F2/Archive Station/32/8	
FIELD 34:0019,10F3/Send Station/33/8	
FIELD 35:0019,1072/Wait flag/34/1	

To configure the system for MAPPED WORKLIST, proceed as follows:

Select RIS settings as illustrated:

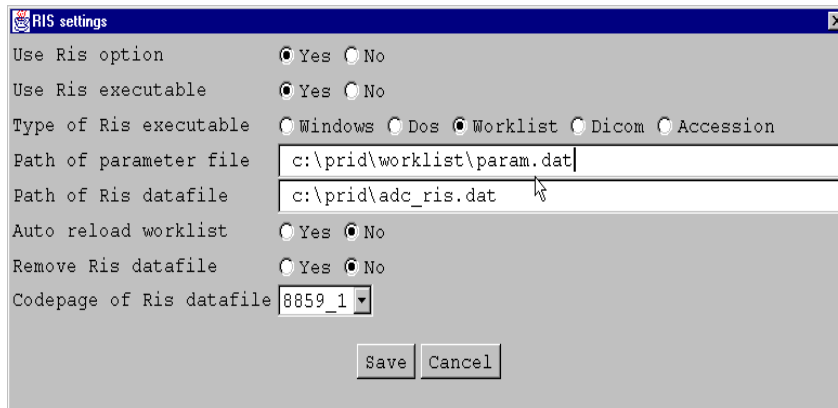

- For “Use RIS option”, select YES.
- The RIS executable is now being used, so click YES.
- The type of RIS executable is Worklist.

- Fill in the path and name of the parameter file. Check if the file exists.
- The path and the name of the RIS data file are defined by the user. In this case: "c:\prid\adc_ris.dat".
- Automatic reload of the worklist will reload the worklist each time a cassette is read, if it is set to YES. As this can be time-consuming, you have the choice of disabling this option.
- Remove RIS data file: with this option you can erase the RIS data file after it has been read and written to the cassette.
- Code page of RIS data file: enables you to determine which code page the RIS data file was created with.

Click SAVE to save your settings.

The file c:\prid\adc_ris.dat contains the data that will be used to fill in the fields in the identification screen. See adc_ris.dat file on pages 4 and 5.

After the cassette has been inserted, the worklist will be shown on the screen:

PatientName	First Name	Birthdate	PatientID
Dow	John	19530916	DJ091601
Johnsson	Peter	19550116	JP550101
Brown	David	19531016	BD531001
Jacobs	Jim	19120916	JJ120901
Chang	Betty	19960916	CB091601
Clark	Peter	19150101	CP010101
Brown	Charlene	19631016	BC101601
Dupont	Brigitte	19700512	DB051201
Van Damme	Jan	19650317	VDJ031701
Peterson	Heidi	19751001	PH100101
Vladimir	Igor	19860416	VI041601
Verstappen	Dieter	19891215	VD121501
Brown	David	19970608	BD060801

- Click the Cancel button to abort the operation.

- Click the Reload button to reread the worklist and update your screen information.
- Click on the patient and then the Select button to select a patient.

The information will be stored in the Identification screen.

The screenshot shows the 'ADC2 IDENTIFICATION STATION <IDEN> IDENTIFICATION SCREEN' window. It contains several sections for data entry:

- PATIENT:** Patient Name (Mr Van Damme), Firstname (Jan), Birth date (17/03/1965), Patient ID (VDJ031701), Sex (Other), and Accession number (Acc_nr_9).
- STUDY:** Radiologist (AGFA DEFAULT), Examination (SERVICE), and Sub examination (CHEST PORTABLE).
- IMAGE:** Department (AGFA ADC2), Patient position (AP), Cassette orientation (Landscape), Exposure Class (200), and Comment (Comment_img9).
- DESTINATIONS:** Hardcopy unit (ADC_LR1), Number of copies (1), Processing station (ADC_PS1), Film format (14INX17IN), Archive station (None), and Send station (None).

At the bottom, there are function keys: F1 Write, F2 Clear, F3 Recall, F4 New patient, F7 History, and F10 Cancel. The status bar shows 'Ready for identification.', 'AUTO', and the date/time '05/06/1997 19:41:55'.

RIS Settings

To gain access to the RIS data file using the DICOM RIS Worklist, proceed as follows:

- Select Ris Settings from the System Manager drop-down menu in the ADC Compact identification screen, as shown below.

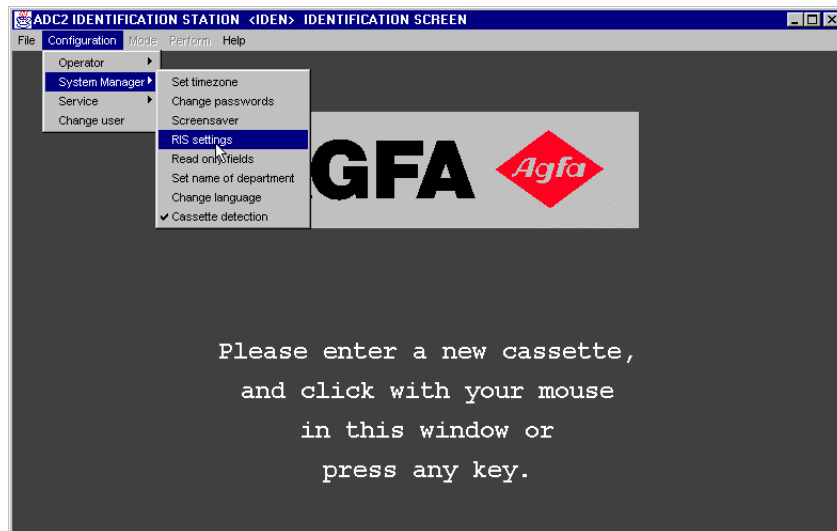

- In the resulting screen, select the following options:

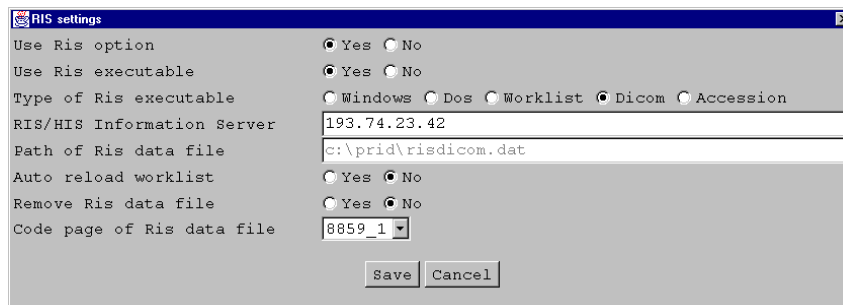

- For **Use Ris option**, select YES.
- The **RIS executable** will be used, so click YES
- If you click YES, the **path of the RIS data file** is fixed and cannot be changed. If you select NO for **Use Ris executable**, the path of the RIS data file which will give access to your own query system must still be defined.
- Select DICOM as the **Type of Ris executable** you will be using.
- As for **RIS/HIS Information Server**, enter the relevant IP address or host name or have this done by the System Manager.
- The **Automatic Reload** of the DICOM worklist should be set to NO for all Worklist-Oriented queries. For Patient-Oriented queries, select YES instead. The system will then automatically reload the DICOM worklist each time a cassette is read and identified, displaying the Query Builder as shown in the screen below.

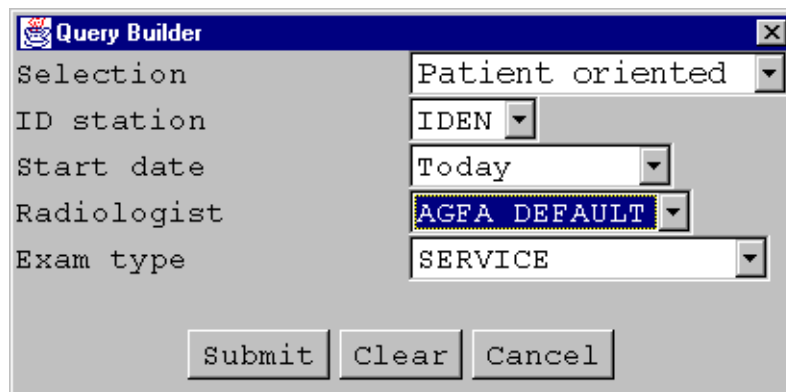

- **Remove RIS data file** : this option enables you to erase the RIS data file after it has been read and written onto the cassette.
- The **Code page of RIS data file** enables you to define which code page the RIS data file is created with.

- Click [SAVE] to store your RIS settings or press [CANCEL] to abort the operation.
The C:\prid\risdicom.dat file contains the data that will be used to complete the fields in the identification screen.

Creation of the DICOM RIS worklist

Query builder

When a cassette is inserted into the ADC Compact Digitizer for the first time, the system will display the Query Builder, as shown in the sample screen below.

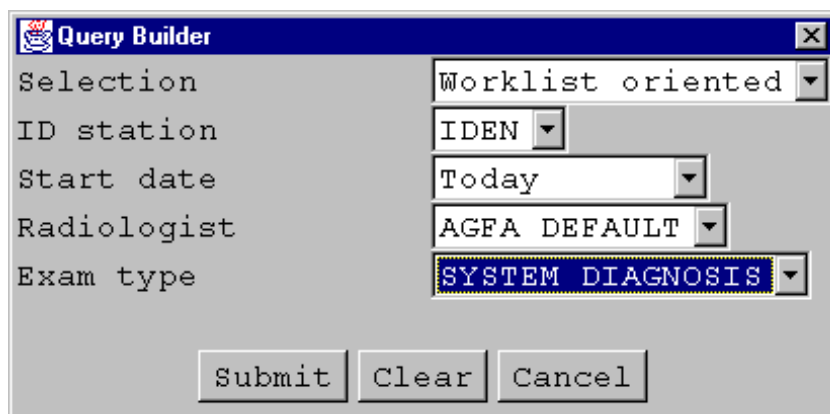

Selection	Worklist oriented
ID station	IDEN
Start date	Today
Radiologist	AGFA DEFAULT
Exam type	SYSTEM DIAGNOSIS

Submit Clear Cancel

As the Automatic Reload has initially been set to NO, the system will not return the Query Builder for subsequent identifications. Instead, it will display the DICOM RIS Worklist proper, whenever a cassette is inserted.

Worklist oriented vs. patient oriented queries

Queries can be initiated using two different methods, viz.:

- Worklist Oriented Query, i.e. a "global" patient list search

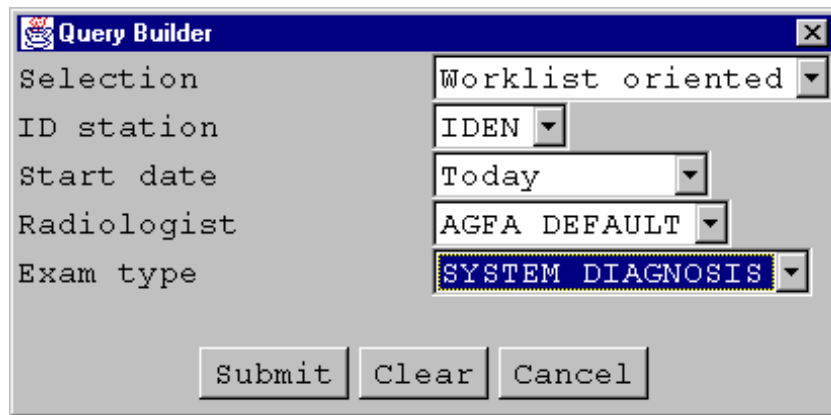

The screenshot shows a 'Query Builder' dialog box with the following fields and values:

Selection	Worklist oriented
ID station	IDEN
Start date	Today
Radiologist	AGFA DEFAULT
Exam type	SYSTEM DIAGNOSIS

Buttons: Submit, Clear, Cancel

- Patient Oriented Query, i.e. a single patient search

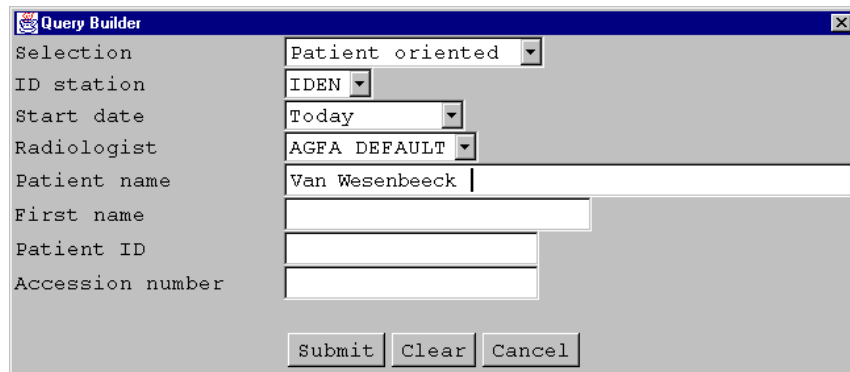

The screenshot shows a 'Query Builder' dialog box with the following fields and values:

Selection	Patient oriented
ID station	IDEN
Start date	Today
Radiologist	AGFA DEFAULT
Patient name	Van Wesenbeeck
First name	
Patient ID	
Accession number	

Buttons: Submit, Clear, Cancel

Worklist oriented Query

In order to initiate a Worklist Oriented DICOM query, proceed as follows:

- Select **Worklist oriented** in the Query Builder screen

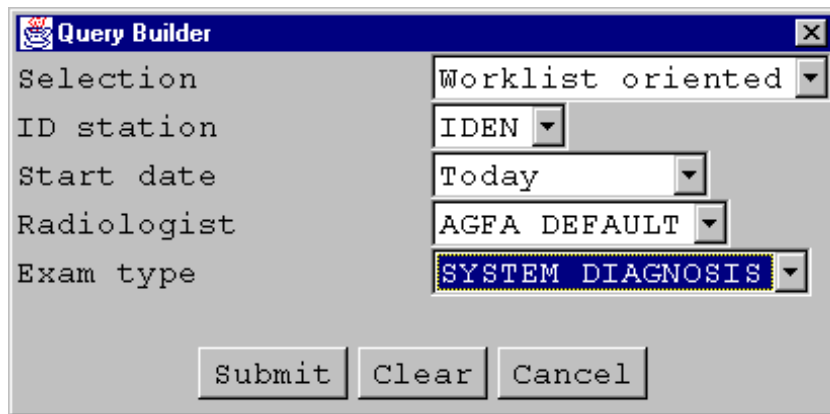

The screenshot shows the 'Query Builder' dialog box. The 'Selection' dropdown is set to 'Worklist oriented'. The 'ID station' dropdown is set to 'IDEN'. The 'Start date' dropdown is set to 'Today'. The 'Radiologist' dropdown is set to 'AGFA DEFAULT'. The 'Exam type' dropdown is set to 'SYSTEM DIAGNOSIS'. At the bottom, there are three buttons: 'Submit', 'Clear', and 'Cancel'.

- Select the appropriate ID station from the ID Station drop-down menu
- In the Start date drop-down menu, select the relevant period you want the Worklist oriented query to be built on.

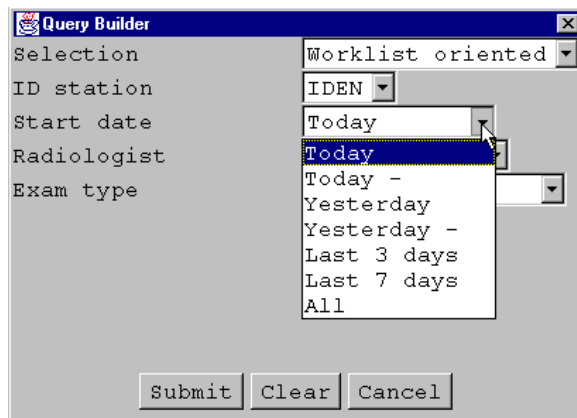

The screenshot shows the 'Query Builder' dialog box with the 'Start date' dropdown menu open. The menu options are: 'Today', 'Today -', 'Yesterday', 'Yesterday -', 'Last 3 days', 'Last 7 days', and 'All'. The 'Today' option is highlighted. The other fields in the dialog box are the same as in the previous screenshot.

- Select the appropriate **Radiologist** and **Exam Type** from the next two drop-down menus.
- Clicking the [CLEAR] button resets the options to their respective default values.

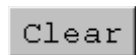

The default values are as follows:

- ID Station the ID Station you are currently working on
 - Start date today
 - Radiologist unchanged
 - Exam type unchanged
- Submit your Worklist Oriented query by pressing the [SUBMIT] button

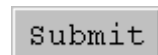

The system displays a waiting message while querying the HIS/RIS.

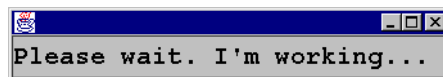

The system queries the RIS, which returns a DICOM worklist to the ID Station, as shown in the sample screen below. The DICOM worklist displays only a few significant DICOM attributes on the basis of which the selection is made. However, you can configure the number of DICOM attributes you want to have displayed on the DICOM worklist.

Accession number	Patient name	Patient ID	Radiologist
63391	Dow John	DJ091601	
63392	Johnsson Peter	JP550101	
63393	Brown David	BD531001	
63394	Jacobs Jim	JJ120901	
63395	Chang Betty	CB091601	SCHEDULED PERFORMING
63396	Clark Peter	CP010101	SCHEDULED PERFORMING
62760	Brown Charlene	BC101601	
62761	Dupont Brigitte	DB051201	
62630	Van Damme Jan	VDJ03170	
62631	Peterson Heidi	PH100101	
63550	Vladimir Igor	VI041601	
63551	Verstappen Dieter	VD121501	

Buttons: Select, Reload, Info, Cancel

- From the DICOM Worklist select the patient record you need. The selected patient is displayed on the Worklist screen in inverted video, as shown below.

Accession number	Patient name	Patient ID	Radiologist
63391	Dow John	DJ091601	
63392	Johnsson Peter	JP550101	
63393	Brown David	BD531001	
63394	Jacobs Jim	JJ120901	
63395	Chang Betty	CB091601	SCHEDULED PERFORMING
63396	Clark Peter	CP010101	SCHEDULED PERFORMING
62760	Brown Charlene	BC101601	
62761	Dupont Brigitte	DB051201	
62630	Van Damme Jan	VDJ03170	
62631	Peterson Heidi	PH100101	
63550	Vladimir Igor	VI041601	
63551	Verstappen Dieter	VD121501	

Buttons: Select, Reload, Info, Cancel

- You can abort the whole operation at any time by clicking the [CANCEL] button.

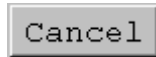

- If you need more exhaustive information on a patient record than the DICOM attributes displayed on the worklist, press the [INFO] button.

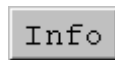

The system then displays the following sample screen.

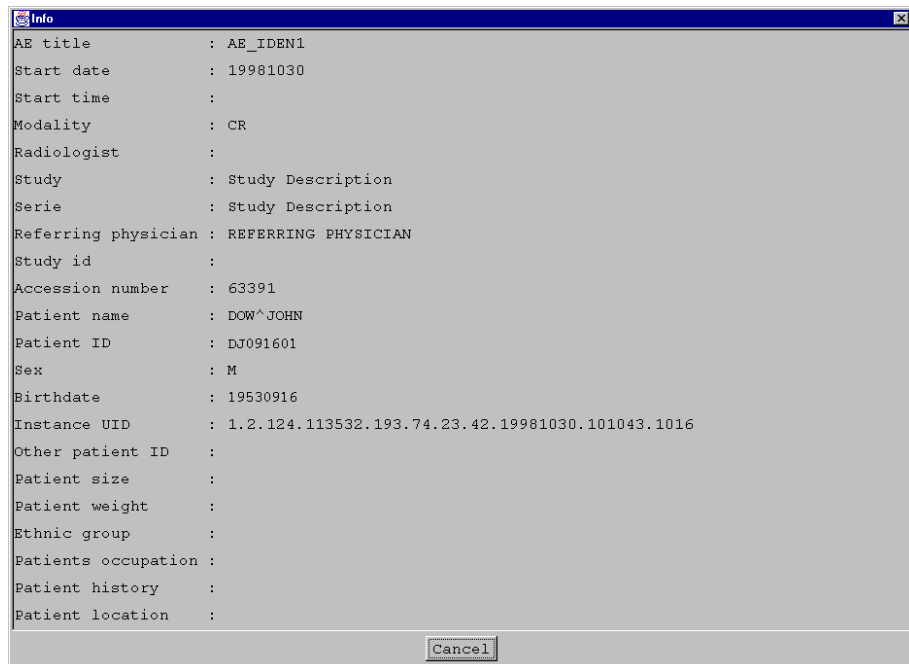

- In order to enter the selected patient record into the ADC Compact identification screen, click the [SELECT] button. The patient record is then written to the **RIS data file** and entered in the identification screen, as shown below.

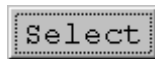

ADC2 IDENTIFICATION STATION <IDEN> IDENTIFICATION SCREEN

File Configuration Mode Perform Help

PATIENT

Patient name: DOW First name: JOHN
 Birth date: 16/09/1953 Patient ID: DJ091601
 Sex: Male Accession number: 63391

STUDY

Radiologist: AGFA DEFAULT
 Examination: SERVICE Sub examination: CHEST PORTABLE

IMAGE

Department: AGFA
 Patient position: AP
 Cassette orientation: Landscape Exposure class: 200
 Comment:

DESTINATIONS

Hardcopy unit: ADC_LR1 Number of copies: 1
 Processing station: ADC_PS1 Film format: 14INX17IN
 Archive station: None
 Send station: None

F1 Write F2 Clear F3 Recall F4 New patient F7 History F10 Cancel

Ready for identification. 12/11/1998 11:10:27

Whenever a new cassette is inserted for identification in the ADC Compact Digitizer, the system returns the DICOM Worklist, displaying the previously selected patient record in ***bold and cursivated typeface***, as shown in the sample screen below.

Accession number	Patient name	Patient ID	Radiolo
63391	<i>Dow John</i>	<i>DJ091601</i>	
63392	Johnsson Peter	JP550101	
63393	Brown David	BD531001	
63394	Jacobs Jim	JJ120901	
63395	Chang Betty	CB091601	SCHEDUL
63396	Clark Peter	CP010101	SCHEDUL
62760	Brown Charlene	BC101601	
62761	Dupont Brigitte	DB051201	
62630	Van Damme Jan	VDJ03170	
62631	Peterson Heidi	PH100101	
63550	Vladimir Igor	VI041601	
63551	Verstappen Dieter	VD121501	

Buttons: Select, Reload, Info, Cancel

- If you click the [RELOAD] button, the Rislink Toolkit software returns the Query Builder screen when a new cassette is inserted into the ADC Compact Digitizer, as shown in the sample screen below.

Using the Query Builder the user can change the query settings if so needed, initiating for a newly arrived patient a Patient Oriented DICOM Worklist query, for example.

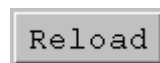

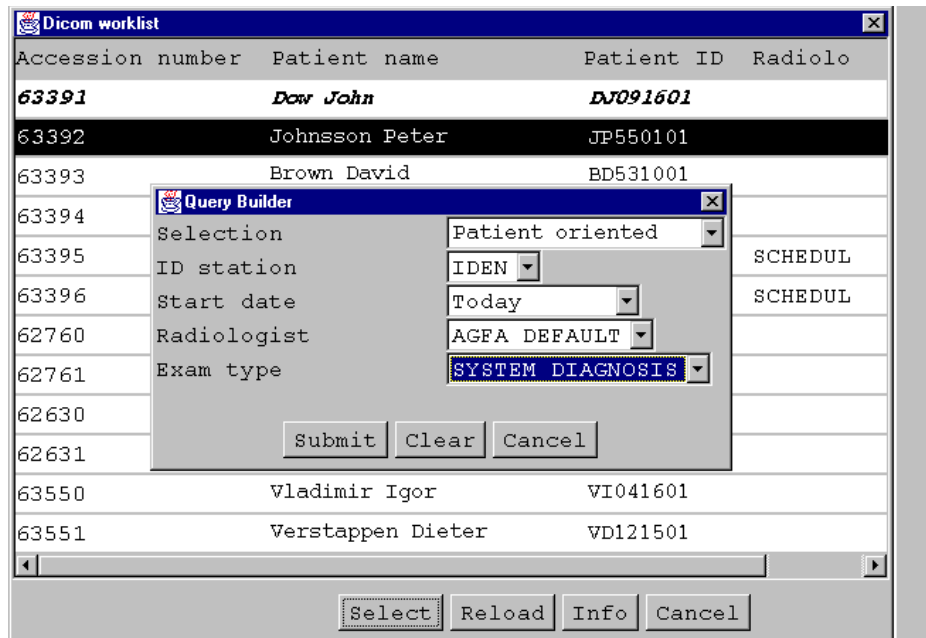

Patient Oriented Query

In order to initiate a Patient Oriented DICOM Worklist query, proceed as follows:

- Select Patient Oriented in the Query Builder screen, as shown

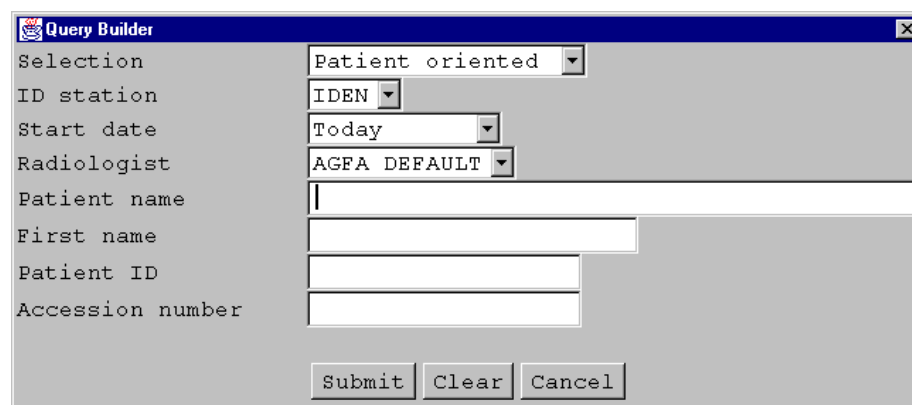

The Patient Oriented Query Builder screen features, in addition to the same drop-down menu options and buttons as in the Worklist Oriented Query Builder screen, a number of additional patient data fields, like

- Patient name
 - First name
 - Patient ID
 - Accession number
- Enter the name of the patient - or Patient ID or Accession number for that matter - you want to perform a HIS query on. In case you fill in all search criteria, viz. the Accession Number, the patient ID and the Patient's Name as search, the system applies the following search priority :
- Accession Number
 - Patient ID
 - Patient's Name

To simplify your task you can resort to the use of so-called wildcards as shown in the sample screen below.

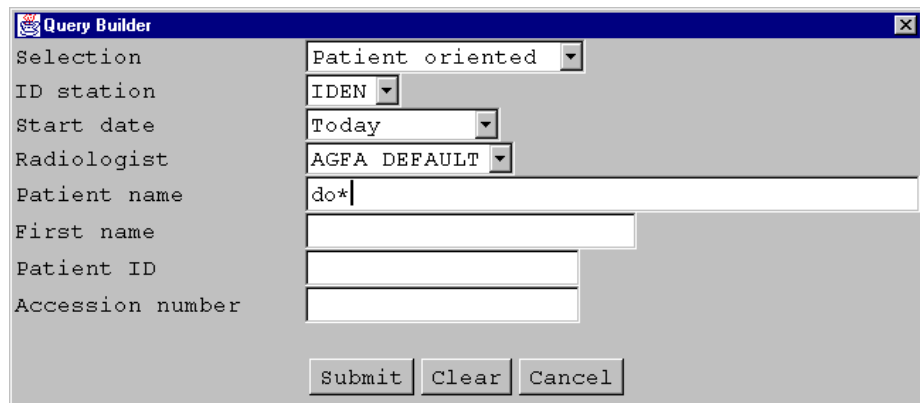

- Clicking the [CLEAR] button resets the options to their respective default values.

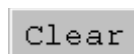

The default values are as follows:

- ID Station the ID Station you are currently working on
 - Start date today
 - Radiologist unchanged
 - Exam type unchanged
- Click the [SUBMIT] button to complete your query.



The system displays the waiting message while querying the HIS/RIS

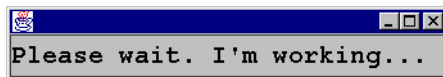

The system then returns a DICOM worklist, as shown in the sample screen below

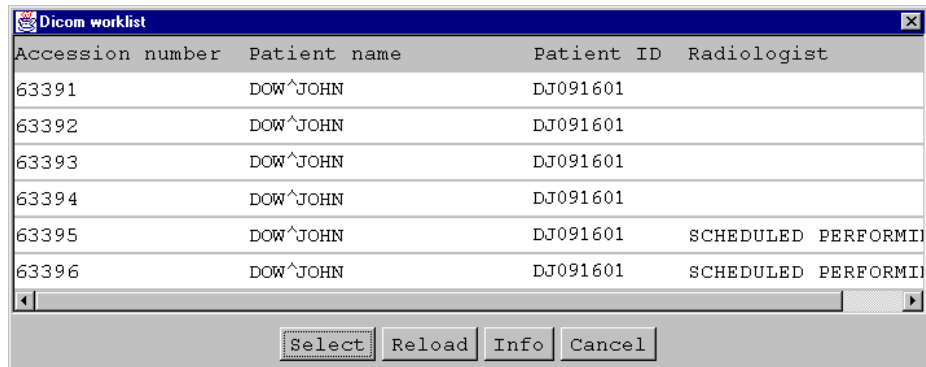

Again, the Patient Oriented DICOM worklist only displays a few significant DICOM attributes (in the sample screen above: Accession number, Patient name, Patient ID and Radiologist). The type and number of DICOM attributes the user wants to have displayed on the worklist is configurable.

- Select the patient record you need from the worklist. The selected patient record is displayed on the Worklist screen in inverted video, as shown below.

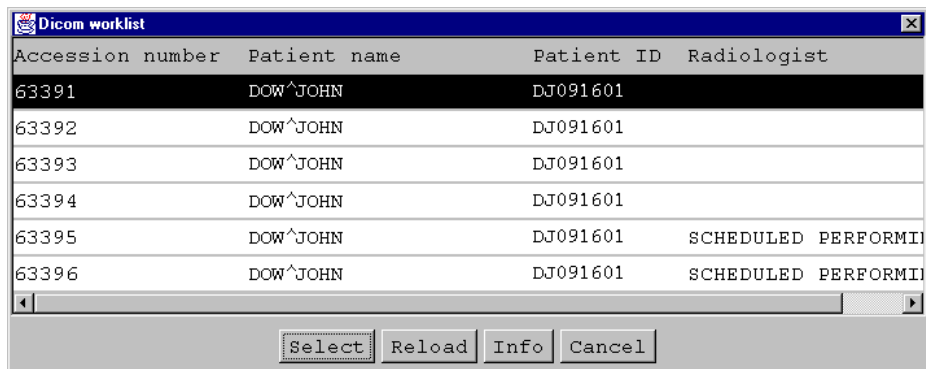

- You can abort the whole operation at any time by clicking the [CANCEL] button



- If you need more exhaustive information on a patient record than the DICOM attributes displayed on the worklist, press the [INFO] button

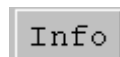

The system then displays the following sample screen

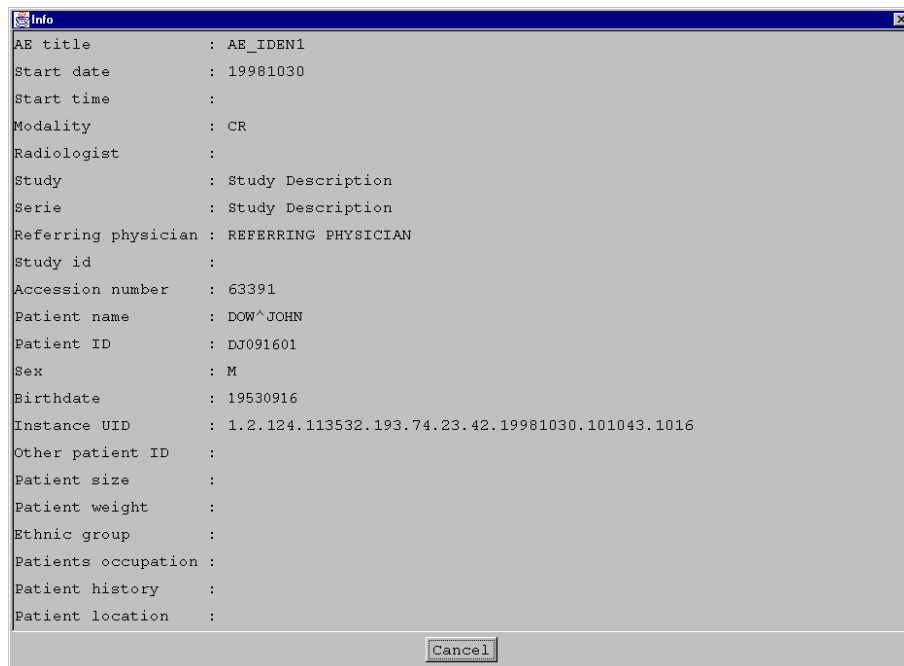

- In order to enter the selected patient record into the ADC Compact identification screen, click the [SELECT] button. The patient record is then written to the **RIS data file** and entered in the identification screen, as shown below.

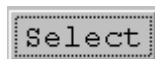

ADC2 IDENTIFICATION STATION <IDEN> IDENTIFICATION SCREEN

File Configuration Mode Perform Help

PATIENT

Patient name: DOW First name: JOHN
 Birth date: 16/09/1953 Patient ID: DJ091601
 Sex: Male Accession number: 63391

STUDY

Radiologist: AGFA DEFAULT
 Examination: SERVICE Sub examination: CHEST PORTABLE

IMAGE

Department: AGFA
 Patient position: AP
 Cassette orientation: Landscape Exposure class: 200
 Comment:

DESTINATIONS

Hardcopy unit: ADC_LR1 Number of copies: 1
 Processing station: ADC_PS1 Film format: 14INX17IN
 Archive station: None
 Send station: None

F1 Write F2 Clear F3 Recall F4 New patient F7 History F10 Cancel

Ready for identification. 12/11/1998 11:10:27

Whenever a new cassette is inserted for identification in the ADC Compact Digitizer, the system returns the DICOM Worklist, displaying the previously selected patient record in ***bold and cursivated typeface***, as shown in the sample screen below.

Dicom worklist

Accession number	Patient name	Patient ID	Radiologist
63391	DOW JOHN	6339	
63392	DOW^JOHN	6339	
63393	DOW^JOHN	6339	
63394	DOW^JOHN	6339	
63395	DOW^JOHN	6339	SCHEDULED PERFORMI
63396	DOW^JOHN	6339	SCHEDULED PERFORMI

Select Reload Info Cancel

- If you click the [RELOAD] button, the Rislink Toolkit software returns the Query Builder screen when a new cassette is inserted into the ADC Compact Digitizer, enabling the user to input new settings.

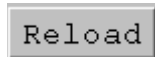

If you input only the Accession Number in the Query Builder screen after Reload, the worklist only displays one line featuring that Accession Number. If on the other hand you submit a query using the Patient ID as a search criterion, the system returns a worklist featuring only one name but several Accession Numbers.

Using Rislink with the Accession Number

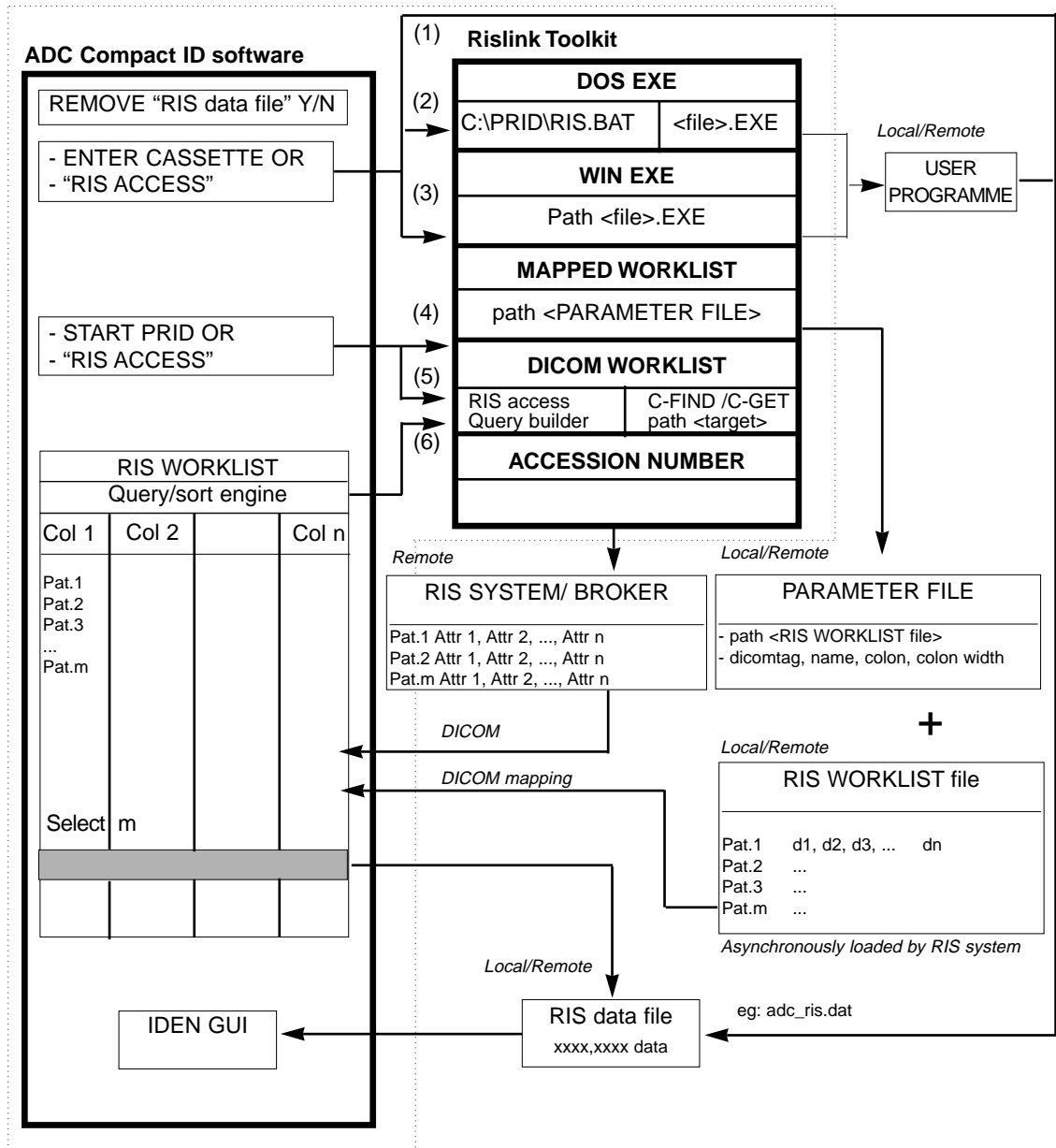

RIS Settings

To gain access to the RIS data file using the Accession Number, proceed as follows:

- Select Ris Settings from the System Manager drop-down menu in the ADC Compact identification screen, as shown below.



- In the resulting screen, select the following options:

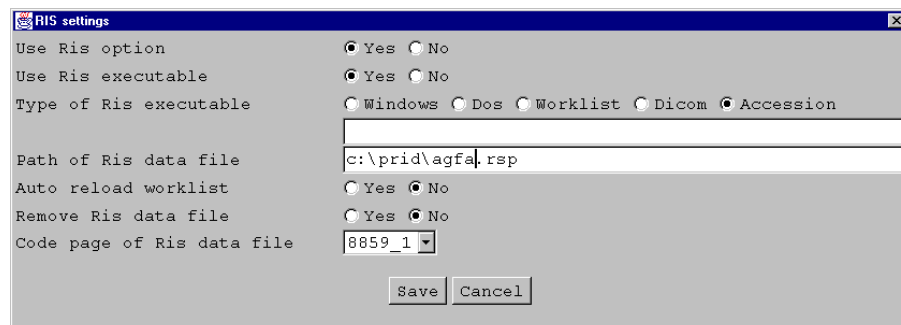

- For **Use Ris option**, select YES.
- The **RIS executable** will be used, so click YES
- Define the **path of the RIS data file**. The extension used should be .rsp, which is short for "response".
- Select **Accession** as the **Type of Ris executable** you will be using.
- The **Automatic Reload** of the DICOM worklist should be set to NO for all Accession Number queries.
- **Remove RIS data file** : this option enables you to erase the RIS data file after it has been read and written onto the cassette. **Remove RIS data file** should be set to NO.
- The **Code page of RIS data file** enables you to define which code page the RIS data file is created with.
- Click [SAVE] to store your RIS settings or press [CANCEL] to abort the operation.

The .rsp file contains the data that will be used to complete the fields in the identification screen.

- Whenever a cassette is inserted for identification, the Rislink Toolkit displays a screen, as shown below

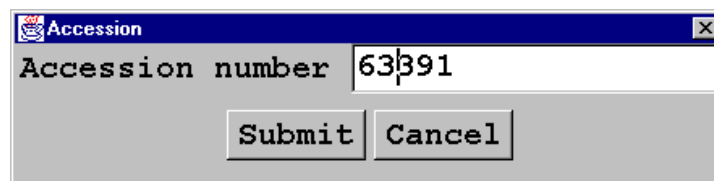

- Fill in the Accession Number and press [SUBMIT]. The system displays a waiting message and creates a request file with the extension .rqt. The broker reads and analyzes this request file and then returns the response file (.rsp), the data of which will show up in the ADC Compact Identification screen.

- If after a 60 sec time-out no response file is returned or if the Accession Number is not available, an error message is shown.



- If the problem persists, call Agfa service.

RIS field mapping

Attribute				
Tag	GUI Name	ACR-NEMA format (V0), ADC 70	DICOM format (V1) ADC Compact	DICOM format (V2) ADC Compact
RISLINK version		RISLINK version 0019,1001	RISLINK version 0019,1001	RISLINK version 0019,1001
PatientName name 10,10	Name	lastname + first name 0010,0010 (33char)	lastname + first 0010,0010	lastname + first 0010,0010
	First name	other names (first name) 0010,1001 (20char)		
PatientID 10,20	Patient ID	patient code 0010,0020 (15char)	patient ID 0010,0020	patient ID 0010,0020
PatientBirthDate 10,30	Birth date	patient birth date 0010,0030 (8char)	birth date 0010,0030	birth date 0010,0030
PatientSex 10,40	Sex	patient sex 0010,0040 (1char)	sex 0010,0040	sex 0010,0040
Accession Number 8,50	Accession number	ris id 0020,0010 (16char)	accession number 0008,0050	accession number 0008,0050
Name Physician Reading Study 8,1060	Radiologist	radiologist 0008,1060 (20char)	radiologist 0008,1060	radiologist performing the study 0008,1050
Study Description 8,1030	Examination	exam type 0019,4000 (20char)	study name 0008,1030	study name 0008,1030
Series Description 8,103E	Sub examination	exam sub type 0019,4001 (20char)	series description 0008,103E	series description 0008,103E
StudyID 20,10	Study ID		study ID 0020,0010	study ID 0020,0010
Study Date 8,20	Study Date		study date 0008,0020	study date 0008,0020

Study Time 8,30	Study Time		study time 0008,0030	study time 0008,0030
Referring Physicians Name 8,90	Physician		referring physician name 0008,0090	referring physician name 0008,0090
Total Number Images 19,1070	Number images in series		total number images 0019,1070	total number images 0019,1070
Study Instance UID 20,D	Study Inst. UID		study instance UID 0020,000D	study instance UID 0020,000D
Institutional Department Name 8,1040	Department		department 0008,1040	department 0008,1040
Cassette Orientation	Cassette orient.	Cassette orientation 0021,0040 (20char)	cassette orientation 0018,1402	cassette orientation 0018,1402
View Position 18,5101	View Position	patient position 0020,0020 (20char)	view position 0018,5101	view position 0018,5101
Sensitivity 18,6000	Exposure Class	exposure class 0019,1262 (20char)	sensitivity 0018,6000	sensitivity 0018,6000
Image Comments 20,4000	Comment	comment 0020,4000 (33char)	comment 0020,4000	comment 0020,4000
	User_info 0	user info field 0010,4000 (12char)	user info 0 0019 10FA	user info 0 0019 10FA
	User_info 1		user info 1 0019 10FB	user info 1 0019 10FB
	User_info 2		user info 2 0019 10FC	user info 2 0019 10FC
	User_info 3		user info 3 0019 10FD	user info 3 0019 10FD
Laterality 20,60	Laterality		laterality 0020,0060	laterality 0020,0060
Series Number 20,11	Series number		series number 20,11	series number 20,11

Body Part Examined 18,15	Body Part		body part 0018,0015	body part 0018,0015
Number of series 19,1060	Number of series		number of series 19,1060	number of series 19,1060
		number of copies 0000,5170 (1char)	number of copies 0019 10FF	number of copies 0019 10FF
		AS destination 0001,5171 (20char)	AS destination 0019 10F2	AS destination 0019 10F2
		PS destination 0001,5172 (20char)	PS destination 0019 10F0	PS destination 0019 10F0
		HCP destination 0001,5173 (20char)	HCP destination 0019 10F1	HCP destination 0019 10F1
			SCP destination 0019 10F4	SCP destination 0019 10F4
		SEND destination 0001,5174 (20char)	SEND destination 0019 10F3	SEND destination 0019 10F3
			wait flag 0019,1072	wait flag 0019,1072
			last of study flag 0019 1071	last of study flag 0019 1071



need conversion to DICOM elements

When the RIS data file is sent by the RIS in the old format, the tags are converted by PRID. The version (old/new) is indicated in the RIS data file with a version parameter. In case the DICOM 0019 1001 (V0: old version; V1: new version; V2: new version) is not present, the system assumes that the old RIS format is used.

RIS value validation

Rules

- General rule: all data and values coming from the RIS are assumed to be valid and can be accepted. They always overrule the automatically generated data from the ID software. The RIS values can be overruled by hand in the ID screen to the extent that the field is configured to be editable.
- Exceptions: when there are conflicts or data cannot be validated, default values are used.

Rislink file formats

Parameter file format

The parameter file is used to map the delimited RISFILE to the IDEN WORKLIST.

- INPUT specifies the path of the worklist to be loaded.
- OUTPUT specifies the path of the RISFILE datafile in which the selected record is written (see Configuration/System/RIS settings; RIS data file)
- COPY not used; only for compatibility.
- SEPARATOR gives the delimiting character of the RIS WORKLIST
When a field should not be mapped, a “*” is entered.

Each field of the separated file is assigned to a certain DICOM element of the ADC Compact ID software. All fields in the RIS WORKLIST must be mentioned, even those which are not mapped.

Example:

```
INPUT:s:\_adc2_f1\tag\worklist.txt
OUTPUT:c:\prid\worklist\Agfa.out
COPY:c:\prid\worklist\Agfa.cop
SEPARATOR:,
FIELD 01:*
FIELD 02:0019,2001/PatientName/1/15
FIELD 03:0019,2002/First Name/2/15
FIELD 04:0010,0030/Birthdate/3/10
FIELD 05:0010,0020/PatientID/4/14
FIELD 06:0010,0040/Sex/5/4
FIELD 07:0008,0050/AccessionNumber/6/4
FIELD 08:0008,1060/Radiologist/7/15
FIELD 09:0008,1030/Study Description/8/10
FIELD 10:0008,103E/Series Description/9/10
FIELD 11:0018,0015/bodypart/10/7
FIELD 12:0020,0010/StudyID/11/5
FIELD 13:0020,000D/Study Instance UID/12/0
.....
```

example: FIELD 02:0019,2001/PatientName/1/15

explanation:

FIELD 02: Field number.

0019,2001: Dicom group number and element number.

patient name: fieldname, can be renamed.

1:sequence in the worklist.

15:number of characters. If "0", not displayed in the worklist.

RIS WORKLIST file format

The RISFILE is a delimited file of worklist fields created by a RIS system (local or remote mounted). The separator is declared in the parameter file (SEPARATOR).

Example:

Normal, img1, 21x43, 19960916, img1_ID, O, Acc_nr_1, AGFA DEFAULT M, SPINE, LUMBAR LAT, , std_img1, , 19970926, 000001, ADC_SQA, , AGFA ADC2, , , , Comment_img1, , , img1_weight, img1_ethnic_grp, img1_info_3, img1_info_4, ADC_LR1, 1, Viewer2, , none, none <CR>

Normal, img2, 21x43, 19960916, img2_ID, O, Acc_nr_2, AGFA DEFAULT M, SPINE, LUMBAR LAT, , std_img2, , 19970926, 000002, ADC_SQA, , AGFA ADC2, , , , Comment_img2, , , img2_weight, img2_ethnic_grp, img2_Info_3, img2_Info_4, ADC_LR1, 1, Viewer2, , none, none <CR>

Normal, img3, 35x43, 19960916, img3_ID, O, Acc_nr_3, AGFA DEFAULT M, CHEST, RIBS UPPER, , std_img3, , 19970926, 000003, ADC_SQA, , AGFA ADC2, , , , Comment_img3, , , img3_weight, img3_ethnic_grp, img3_Info_3, img3_Info_4, ADC_LR1, 1, Viewer2, , none, none <CR>



Printed in Belgium
Published by Agfa-Gevaert N.V. , B-2640 Mortsel-Belgium
2209C GB 199903

